

## VR INTER-DRY



### Main features

VR INTER-DRY couplings are used for quick connections and/or disconnections of pipes and hoses where fluid leakage must be avoided. VR INTER DRY has been designed to ensure complete interchangeability with Emco, Mann Tek, Avery Hardoll and Todo connections.

- The valves open and close simultaneously during the connection/disconnection of the parts
- The closure of the internal valves is ensured before the disconnection
- Fast and safe connection and disconnection even in the presence of pressure and flow (if necessary)
- Extremely reliable, very few moving parts
- Strong construction, no external active component
- Reduces fluid leakage to virtually zero, improving efficiency
- Reduces the possibility of human error
  
- **Std. material:** AISI 316L
- **On request:** aluminum, bronze

**Fittings:** Threaded or flanged ends (BSP, BSPT, NPT / UNI, ASA, TW e TTMA).

**Operating pressure:** 16 bar (10 bar for 6")

**Dimensions:** 1 ½" (DN 40), 2" (DN 50), 3" (DN 80), 4" (DN 100), 6" (DN 150)

### Certifications

- CE marked in accordance with PED 2014/68/UE
- ATEX Directive 2014/34/UE

## How does it work?

With a first rotation of about 15°, the two parts are firmly joined together.

In this position the valves are still closed and they open only with further rotation, thus ensure the liquid flow.

To close the valves and to separate the two parts, repeat the connection procedure in the opposite sequence.

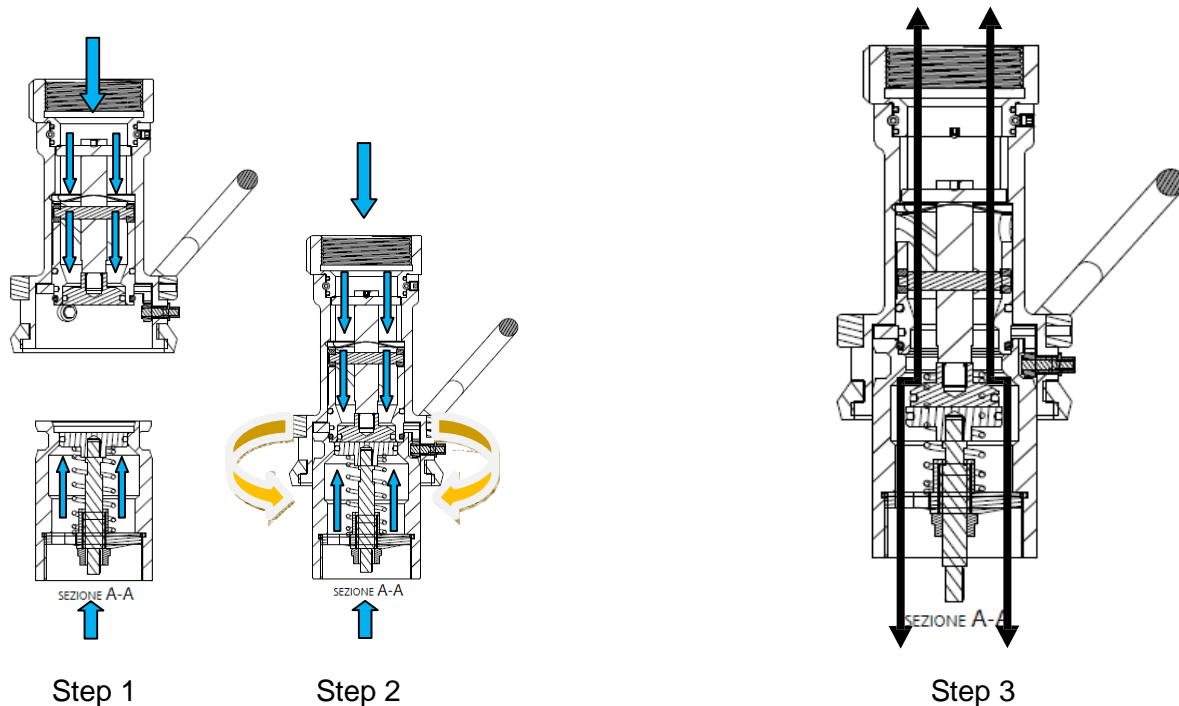

Technical Data	
DIAMETER	WORKING PRESSURE
Inch	bar
1.1/2" – 2" – 3" – 4"	16
6"	10

Temperature Range	
GASKET	TEMPERATURE
Material	[°C]
NBR	-40°C ÷ +110°C
EPDM	-50°C ÷ +150°C
VMQ	-50°C ÷ +200°C
FPM / FKM	-20°C ÷ +200°C
FFKM	-15°C ÷ +315°C